

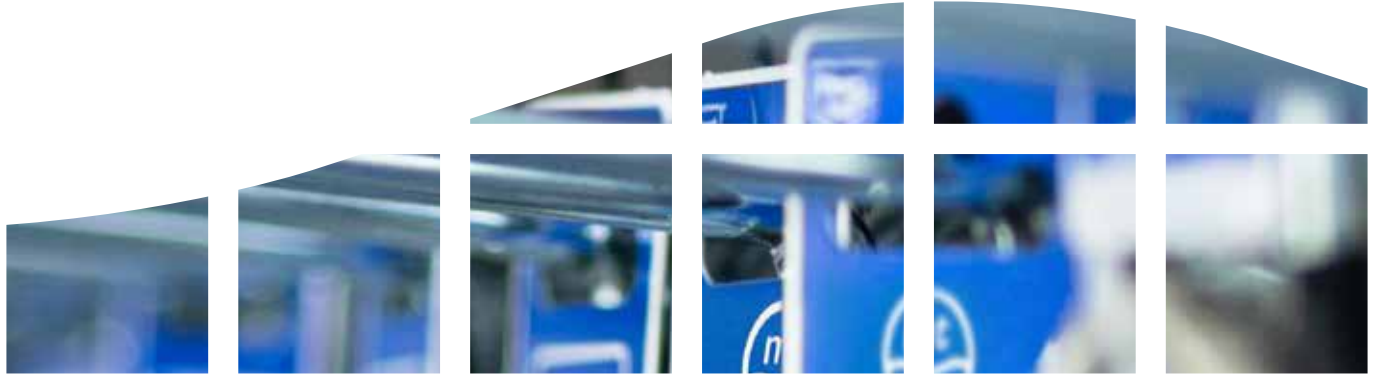

marinotech
stainless steel fasteners



POS service

for your success at your point of sale –
online and in store: Images, displays, packaging,
systems and much more ...

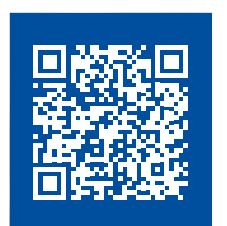
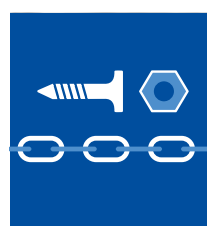
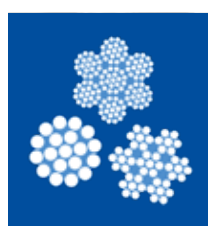
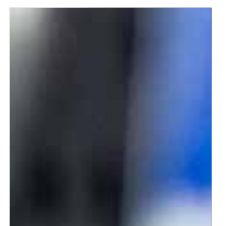
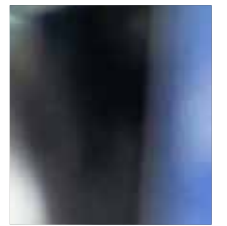

» *A plus for retailers*



One of the largest ranges of stainless steel fasteners in Europe

Over 38,000 items – in different variations and sizes

- > Precise quality control – for maximum product quality
- > good product availability
- > Fast delivery – through reliable partners in transport & logistics

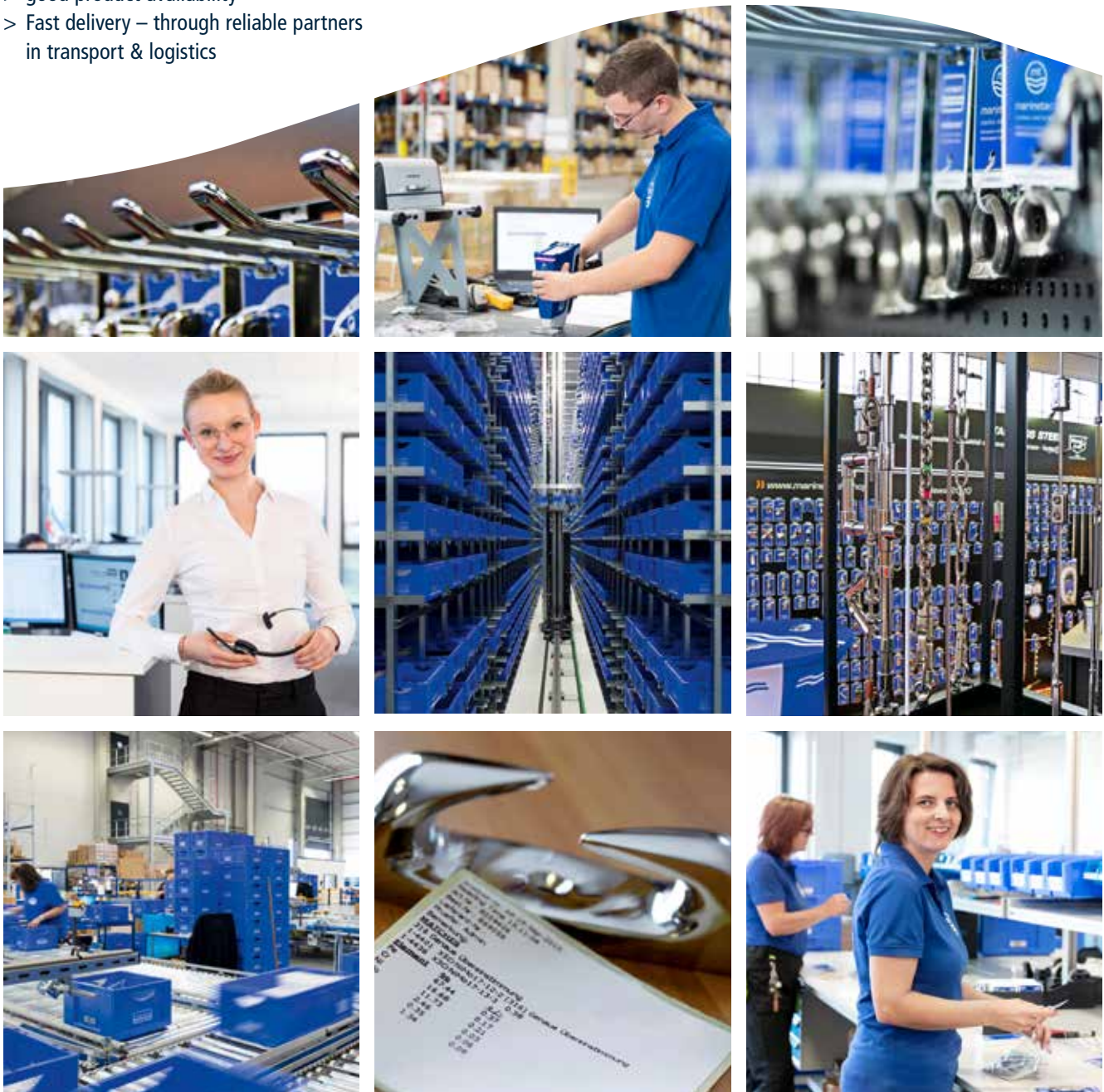

» *Your service and POS advertising team*

Experienced marketing professionals will help you on site & online with advice on marketing.



Easy to contact

Whether by phone, e-mail, in an online meeting or in person – together we will find the best solution for you.



Tel. +49 421 - 690 56 - 0

Mail pos@marinetech.de

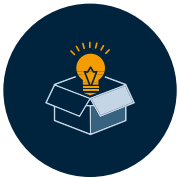

Extensive expertise

Our technical expertise and creativity will bring your visions to reality. We have many years of experience in the DIY sector and offer you innovative ideas and customised solutions. In online retail and on site. Including the EDI-process.



Good packaging concepts

We offer you a wide range of presentation and packaging options. On the following pages we'll give you an overview. All Data and images are available in digital form.



Increase in sales

With the right measures at the point of sale, you can present your product range in the best way, optimize customer attention and therefore increase your sales figures.



» *At home and everywhere*

**Trade – Industry – Maritime – Architecture –
Sport and Leisure – Agriculture ...**



Our products are universally applicable, which is why we are aware of customer interests in many different industries. Accordingly, we can support you with our experience for your marketing and sales.

In store

On site – be tangible and inspire customers in person

Use your 'locational advantage' over online retail: meet your customers in person.

Be visible, up-to-date and inspiring at all times. Offer a pleasant and successful shopping experience. An informative, detailed product presentation not only increases customer satisfaction, it also takes the pressure off your employees in the customer consultation. A win-win situation for everyone!

In online retail

Ready at any time: Online retail sets other priorities

Fast delivery, wide product range and shopping from the comfort of your own home – these customer requirements mean that all items need to be quickly recognisable and attractively presented for a successful online appearance. Therefore we support you with image and text material, optimised availability, transport and logistics.

Because with the right presentation at the point of sale, customer needs become shopping baskets and shopping baskets become purchases and an increase in sales.



You will find an overview of our POS systems for online and in store sales as well as further details on the following pages of this brochure as well as on our website.

POS-Service

» *Personalised and customised to your needs*

It's all about the right range. Suitable for your market and to your customer needs. That's why we adapt to you:

1. Customised item selection – ready to use

Design your own sales displays by selecting the products and quantities you require. We deliver your displays fully assembled with window packaging or open blister cards, including item description, item number and EAN code. Based on your needs. A sophisticated merchandise management system supporting the whole process.

2. Personalised advice – also on site

All product presentation options will be explained and listed in detail.

3. Customised labelling and printing – bringing your logo into focus

From screw stands to blister cards, you can have everything customised and printed according to your specifications. In your personalised corporate design.

4. Customised data exchange

EDI – exchange of warehouse data and transmission of current stock levels for seamless integration into your systems are a matter of course for us.



Whenever you see this sign

we can customise the packaging for you, add your logo, a slogan or advertising message (to address the customer specifically).

Customised products

Can't find the presentation you have in mind? Do you have something very special in mind? Do you want a more extensive POS reorganisation? Just ask us:

Tel. +49 421 - 690 56 - 0

Mail: pos@marinetech.de

» *Packaging and display systems*

for stationary retail as well as for DIY stores.
Sales stands, displays, perforated walls, blister cards and so much more.

For small and large presentation areas. Options on the wall, on the floor or at the counter.

Packaging and displays also available in smaller quantities.

Optimised for all Marinetech items.



» Stands and displays

Eye-catchers: attractive product presentations

Eye-catching, durable, safe. Easy to use, easy to maintain and easy to fit into your store. We offer a wide range of options for presenting our products in store and support you in choosing the best option for your needs.



Screw rack for self-service boxes

Ready to use, customised or with our standard range of screws, washers and nuts



in A2/ AISI-304,
No 800002SB



or A4/ AISI-316
No 900004SB

Rotating sales stand:

- Space for 245 different common screw dimensions
- Space-saving dimensions! Floor space: approx. 1 m², height: approx. 2 m
- No different price groups
- Self-service boxes with viewing window, product image and EAN code
- Easy reordering of self-service boxes in boxes of 10
- Material: steel, painted in blue or black



Self-service sales racks `compact`: Flexible product distribution in self-service boxes or on blister cards

Nr. SB0001ST

Sturdy swivelling sales stand:

- Space for up to 200 items
- Space-saving dimensions: four sides, each 0.30 m wide
- Floor space: approx. 0.5 m², height: approx. 1.80 m
- Material: steel, painted black



Table and counter display: can be organised flexible, for screws and other fasteners in self-service boxes or on blister cards

For special offers and product presentation in small spaces.
Available in different versions.



Sales wall with hooks: Customized product distribution in self-service boxes and on blister cards

Ready to use, customised or with our standard range.
The blister wall is an attractive way to display your product range. It
consists of modules in different designs and can be extended as required.

- Module dimensions: Width: 1.25 m, height: approx. 2.20 m
- Material: steel, painted black (perforated plate)
- Selection of various hook lengths, e.g. 100 mm or 200 mm

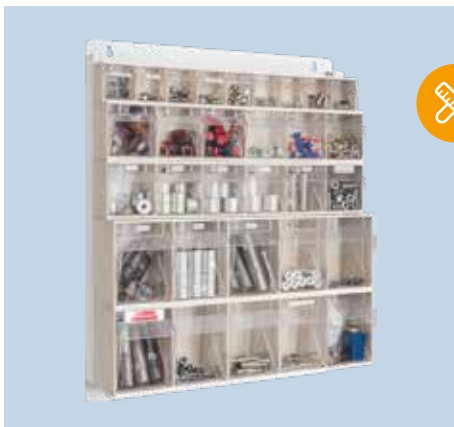

Multistore system with transparent tipping containers

The optimal solution for organisation, overview and dust-free storage.
The system offers different box sizes which have the same shelf width.
The tipping containers can be tilted forward or removed completely. There are
no limits to the width and height extensions. Mounted on the wall or as free-
standing shelves.

- Example equipped with: 1 x 9-box, 2 x 6-box, 2 x 5-box
- External dimensions example: 601 x 163 x 730 mm
- Material: plastic



Cardboard box with your imprint or in Marinotech design

Depending on the item and quantity specification,
we manufacture the displays individually according to your needs
from high-strength, durable cardboard.

We will be happy to visit you on site, work with you to analyse your
spatial possibilities and develop a plan that takes into account the
product selection and the possibility of your own packaging.

» For the online retail ...

Optimise your online sales with our solutions

Do you sell Marinetechnik products in your own webshop? We will be happy to provide you with high-quality image and text material and support you with our expertise – for successful E-commerce.



Product images

Professional, high quality and detailed photos as cut-outs – for an appealing and informative product presentation for desktop and mobile devices.



Image pictures

On request, you can also receive attractive application pictures. Talk to us about it!

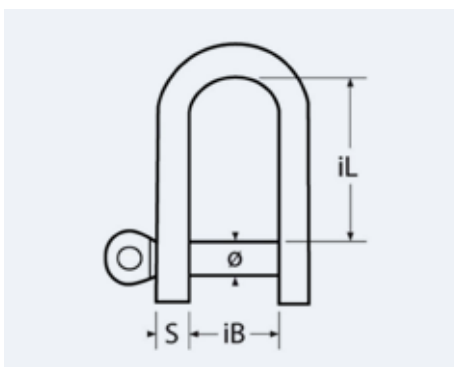

Technical information and dimensional drawings

Precise technical drawings with dimensions for all items. Also tables with sizes and quantities etc.

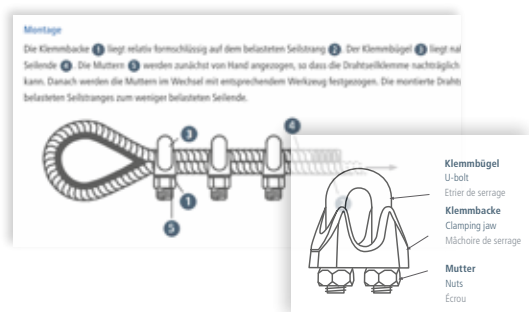

Manuals and operating instructions

Clearly structured and easy-to-understand instructions, some as videos for complex multi-part products that require explanation.

» Meet Marinetechnik online

» www.marinetechnik.shop/en » www.marinetechnik.de/en

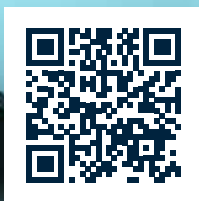

Webshop



Newsletter

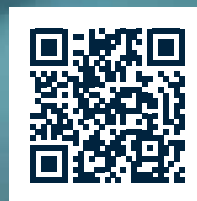

Website



LinkedIn



Instagram



YouTube

Follow us on LinkedIn, Instagram and Youtube to always get the latest updates! Be the first to find out about interesting promotions and get exclusive insights behind the scenes.

***Marinotech Edelstahlhandel
GmbH & Co. KG***

Marschgehren 16 · 28779 Bremen
Deutschland / Germany

Tel. +49 421 - 69056 - 0
Fax +49 421 - 69056 - 50
info@marinotech.de

» [*www.marinotech.shop*](http://www.marinotech.shop)

» [*www.marinotech.de*](http://www.marinotech.de)

Follow us also on

